

Owner's Manual

**CRAFTSMAN®**

**36" TOW-BEHIND  
UNIVERSAL TILLER  
Model No. 486.252444**

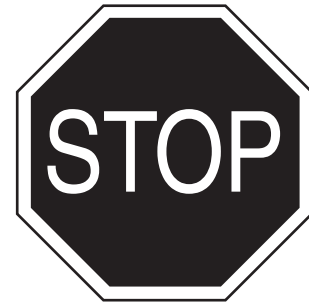

DO NOT RETURN TO STORE  
For Missing Parts or Assembly  
Questions Call 1-866-576-8388

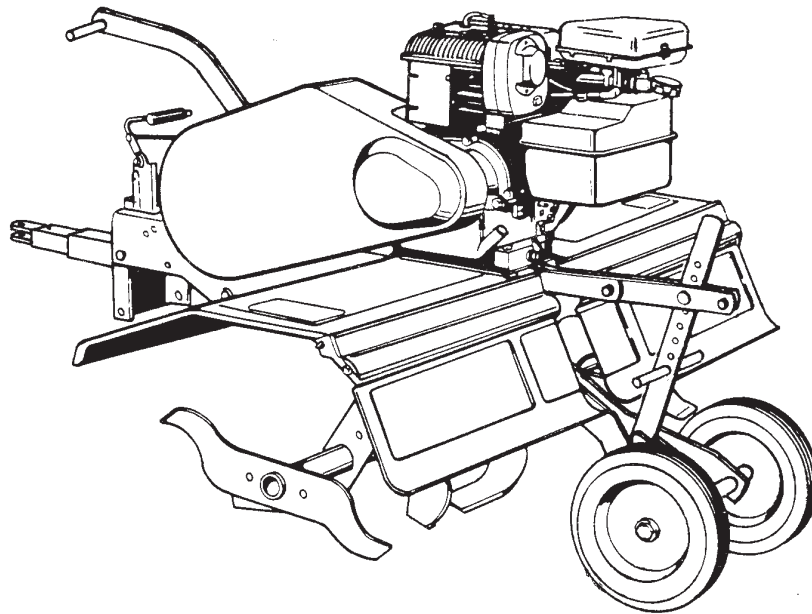

**CAUTION:**

Before using this product, read this manual and follow all Safety Rules and Operating Instructions.

- Safety
- Assembly
- Operation
- Maintenance
- Parts

Sears, Roebuck and Co., Hoffman Estates, IL 60179 U.S.A.  
[www.sears.com/craftsman](http://www.sears.com/craftsman)

PRINTED IN U.S.A.

FORM NO. 49940 (04/24/08)

# TABLE OF CONTENTS

WARRANTY .....	2	SERVICE AND ADJUSTMENT .....	11
SAFETY RULES.....	3	STORAGE .....	12
ASSEMBLY.....	4	TROUBLESHOOTING.....	13
OPERATION.....	6	REPAIR PARTS .....	14
MAINTENANCE .....	9	PARTS ORDERING/SERVICE .....	Rear Cover

**LIMITED WARRANTY ON CRAFTSMAN POWERED TRACTOR ATTACHMENTS**

For one (1) year from the date of purchase, if this Craftsman Equipment is maintained, lubricated and tuned up according to the instructions in the owner's manual, Sears will repair or replace free of charge any parts found to be defective in material or workmanship. Warranty service is available free of charge by returning your Craftsman equipment to your nearest Sears Service Center. In-home warranty service is available but a trip charge will apply. This Warranty applies only while this product is in the United States.

**This Warranty does not cover:**

- Expendable items which become worn during normal use, such as spark plugs, air cleaners, belts, and oil filters.
- Tire replacement or repair caused by punctures from outside objects, such as nails, thorns, stumps, or glass.
- Repairs necessary because of operator abuse, including but not limited to, damage caused by impacting objects that bend the frame or crankshaft, or over-speeding the engine.
- Repairs necessary because of operator negligence, including but not limited to, electrical and mechanical damage caused by improper storage, failure to use the proper grade and amount of engine oil, or failure to maintain the equipment according to the instructions contained in the owner's manual.
- Engine (fuel system) cleaning or repairs caused by fuel determined to be contaminated or oxidized (stale). In general, fuel should be used **within 30 days** of its purchase date.
- Equipment used for commercial or rental purposes.

**LIMITED WARRANTY ON BATTERY**

For ninety (90) days from date of purchase, if any battery included with the equipment proves defective in material or workmanship and our testing determines the battery will not hold a charge, Sears will replace the battery at no charge. Warranty service is available free of charge by returning your Craftsman equipment to your nearest Sears Service Center. In-home warranty service is available but a trip charge will apply. This Warranty applies only while this product is in the United States.

TO LOCATE THE NEAREST SEARS SERVICE CENTER OR TO SCHEDULE SERVICE, SIMPLY CONTACT SEARS AT 1-800-4-MY-HOME.

This warranty gives you specific legal rights, and you may also have other rights, which vary from state to state.

Record serial number and date of purchase in space provided below.

MODEL NUMBER: <u>486.252444</u>
SERIAL NUMBER: _____
DATE OF PURCHASE: _____
The model and serial numbers will be found on a plate attached to the right hand chassis.
You should record both serial number and date of purchase and keep in a safe place for future reference.

**PRODUCT SPECIFICATIONS**

GASOLINE TYPE	REGULAR UNLEADED
OIL TYPE	SAE 30 (ABOVE 32° F)
(API-SF/SG)	SAE 5W-30 (BELOW 32° F)
OIL CAPACITY:	20 OZ.
SPARK PLUG	(GAP .030")
TILLING GROUND SPEED	Approx. 2 MPH
TILLING WIDTH	36 INCHES
TILLING TINE SPEED	200 RPM



# SAFETY



**WARNING:** This cutting machine is capable of amputating hands and feet and throwing objects. Failure to observe the following safety instructions could result in serious injury or death.

## IMPORTANT

Warnings, Cautions, and Notes are a means of attracting attention to important or critical information in this manual.



Look for this symbol to point out important safety precautions. It means-**Attention! Become Alert!** Your safety is involved.

## TRAINING

- Read opening and Service instructions carefully. Be thoroughly familiar with the controls and the proper use of the equipment.
- Never allow children to operate the machine. Do not allow adults to operate the machine without proper instruction.
- Keep the area of operation clear of all persons, particularly small children and pets.

## PREPARATION

- Check the fuel and lubrication before starting the engine. Do not fill the gasoline tank indoors when the engine is running or while the engine is still hot. Wipe off any spilled gasoline before starting the engine.
- Inspect the area to be tilled. Remove glass, wire, metal objects, large sticks, and stones. Avoid underground pipes and wiring.
- Have a complete working knowledge of your tractor and know how to handle your tractor with a tiller or other attachment attached.

## OPERATION

- Give complete and undivided attention to the job at hand. Operate the tiller in daylight or good artificial light.
- Personal injury may result from contact with the augers or debris thrown by this machine. Therefore, always stay a safe distance away from the augers.
- Stop the tiller engine when leaving your tiller unattended.
- Check before each use for loose fasteners or parts.
- Never store the equipment with gasoline in the tank inside of a building where fumes may reach an open flame or spark. Allow engine to cool before storing in an enclosure.

- Stop engine and disconnect spark plug lead wire before cleaning augers, removing obstacles, or making adjustments, except for those which must be done with the engine running.
- Never place hands or feet under or into rotating parts or concealed areas. Keep hands and feet clearly away from auger elements, belts, pulleys, etc. while engine is running.
- Wear substantial shoes and eye protection while using tiller.
- Never attempt to make a maintenance adjustment while engine is running, except on the carburetor.
- Do not run the engine indoors; carbon monoxide fumes are dangerous to inhale.
- Never operate machine without proper guards, plates, or other safety protective devices in place.
- Disengage the Tine Clutch Lever, stop tiller and tractor engines before getting off the tractor.
- Disengage the Tine Clutch Lever and stop the tiller engine during transportation to and from the work area.

## MAINTENANCE AND STORAGE

- Follow maintenance instructions as outlined in this manual and your Engine Owner's Manual supplied with the unit.
- Disconnect spark plug wire before making maintenance adjustment or repair.
- Store gasoline in an approved metal container in a cool, dry place.
- Safety and performance levels can be assured only by the use of specified replacement parts.



**WARNING:** This unit is equipped with an internal combustion engine and should not be used on or near any unimproved forest-covered or grass-covered land unless the engine's exhaust system is equipped with a spark arrester meeting applicable local or state laws (if any). If a spark arrester is used, it should be maintained in effective working order by the operator. In the state of California, the above law is required by law (Section 4442 of the California Public Resources Code). Other states may have similar laws. Federal laws apply on Federal lands. A spark arrester for the muffler is available through your nearest Sears Authorized Service Center.

## ASSEMBLY

### TO REMOVE UNIT FROM CARTON

- Cut from top to bottom all four corners of the carton and lay panels flat. (See Fig. 1)
- Remove the lag screw that holds the floating hitch to the packing skid.
- Disassemble and discard carton's wood top and side supports.
- Remove four hex bolt, hex nuts and flat washer from the hold down brackets at the rear of the carton.
- Remove and **save** the two Flat Washers and Cotter Pins from the rear axle. Reuse when attaching gauge wheels.
- Discard all other packing hardware and hold down brackets.

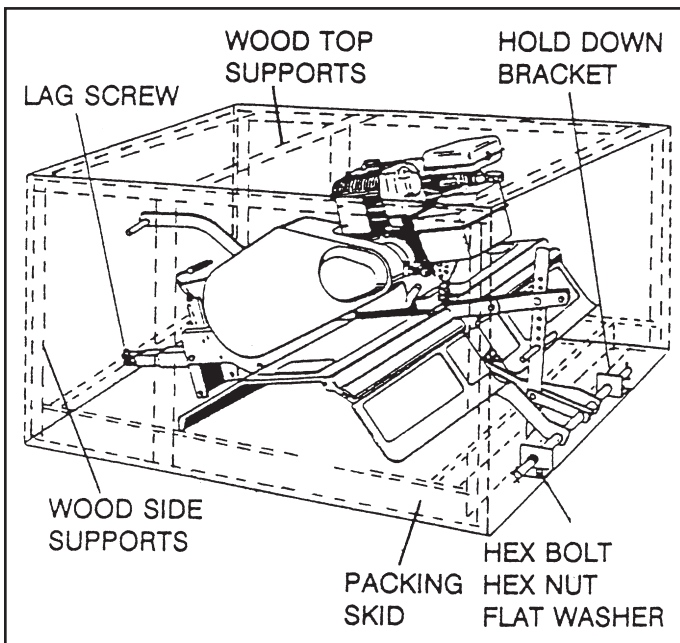

FIG. 1

- Right hand (RH) and left hand (LH) are determined from the drivers position while seated on the tractor.
- We recommend that you remove the Mower Deck before using the Tiller. Refer to your Tractor Owner's Manual.

### TO INSTALL THE TILLER GAUGE WHEELS

- Assemble Gauge Wheels onto the Rear Axle with the extended end of Hub facing inward. Secure with the Flat Washers and Cotter Pins which you removed from the axle during unpacking. (See fig. 2.)

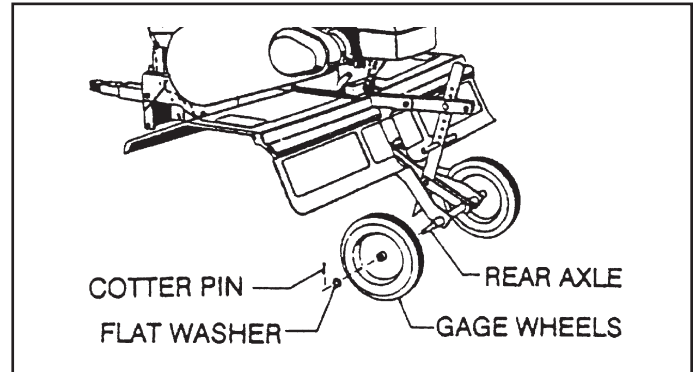

FIG. 2

### TO INSTALL THE TILLER TINE ASSEMBLIES

- Attach the floating hitch to the tractor's draw bar. (Refer to Operating Instructions on page 7.)
- Remove the preassembled 3/8" x 2" hex bolt and 3/8" nylock nut from the L.H. Tine Assembly. Slide the tine assembly onto the Transmission Axle on the left side of the tiller and secure with the hex bolt and nylock nut. (See fig. 3.) Repeat for the R.H. side.

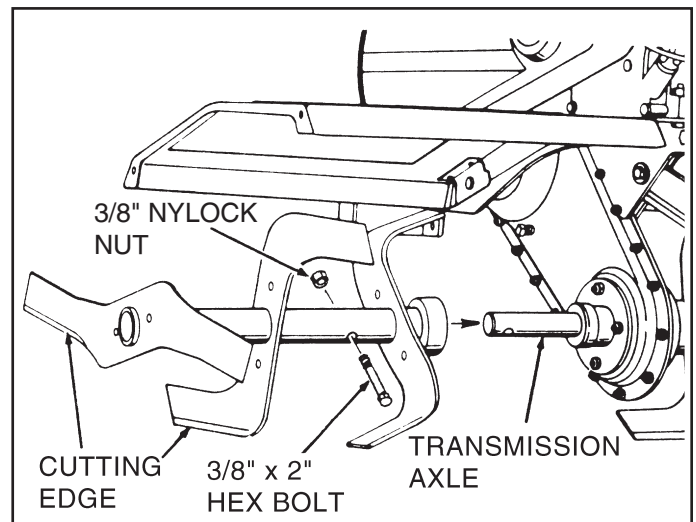
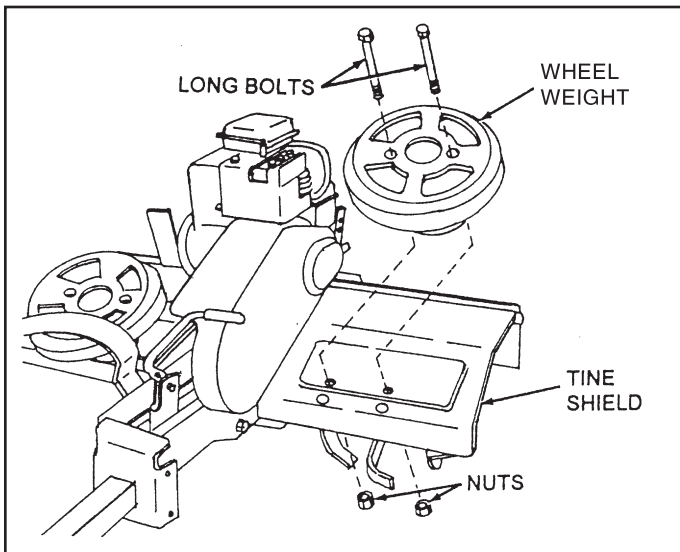

FIG. 3

# TO INSTALL (WHEEL) WEIGHTS TO TILLER

**NOTE:** Weights are not furnished with the Tiller. 30 lb. tractor wheel weights may be purchased to mount to the Tiller if extra weight is required. (Refer to the Operation section of this manual.)

- Remove two Carriage Bolts and Nuts from each Tine Shield, located approximately 3-1/2" from the front edge. See fig. 4.
- Place (Wheel) Weights on Tine Shield and secure with long Bolts and Nuts furnished with the Weights. See fig. 4.



**FIG. 4**

# OPERATION

## KNOW YOUR TILLER

READ THIS OWNER'S MANUAL AND SAFETY RULES BEFORE OPERATING YOUR TILLER.

Compare the illustrations with your tiller to familiarize yourself with the location of various controls and adjustments. Save the manual for future reference.

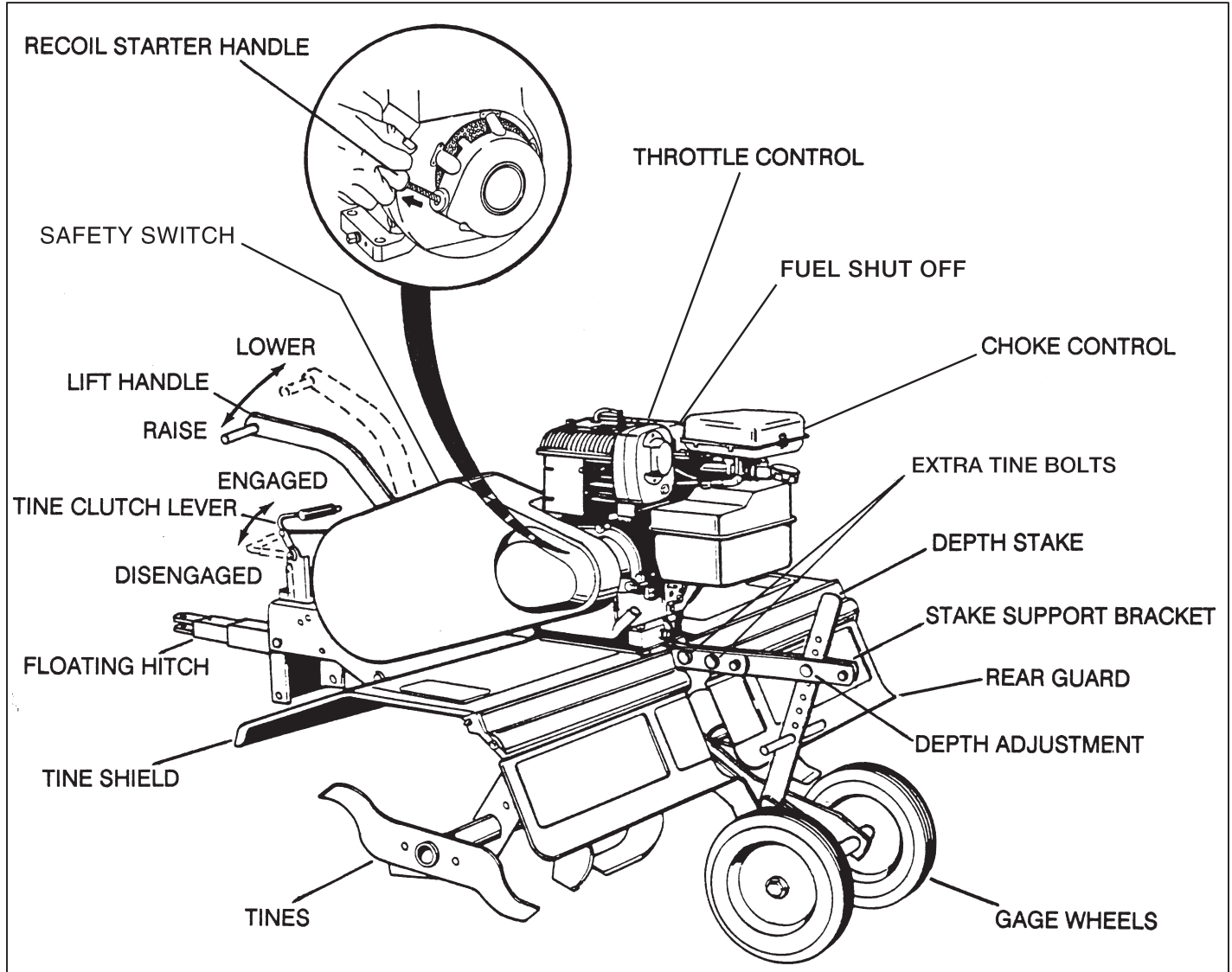

FIG. 5

**SAFETY SWITCH** - prevents engine from starting while tine clutch lever is engaged

**LIFT HANDLE** - selects tilling or transport position by moving gage wheels

**TINE CLUTCH LEVER** - starts and stops tine rotation

**FLOATING HITCH** - telescoping hitch limits shock loads to tractor

**RECOIL START HANDLE** - used to start the engine

**THROTTLE CONTROL** - controls engine speed

**FUEL SHUT OFF** - shuts off fuel to engine

**CHOKE CONTROL** - used when starting a cold engine

**DEPTH STAKE** - controls tilling/cultivating depth



The operation of any tiller can result in foreign objects thrown into the eyes, which can result in severe eye damage. Always wear safety glasses or eye shields before starting your tiller and while tilling. We recommend a wide vision safety mask for over the spectacles or standard safety glasses.

## HOW TO USE YOUR TILLER

### BEFORE STARTING YOUR TILLER

**FILL THE ENGINE WITH OIL!** Your tiller engine is shipped without oil or gasoline. Add oil and gas as instructed in the separate engine manual.



**WARNING:** Never fill fuel tank indoors, or with the engine running, or while the engine is hot. Do not smoke while filling tank.

### STOPPING YOUR TILLER

#### TINES

- Raise tiller to transport position.
- Pull forward on tine clutch lever.

ENGINE (Refer to separate engine manual.)

- Move throttle control to "STOP" position.
- Turn shut off to "OFF" position.
- Never use choke to stop engine.

### STARTING YOUR TILLER

(Refer to separate engine manual.)



**CAUTION:** The muffler and adjacent areas are hot!

- Check oil and gas in Tiller engine.
- Attach spark plug wire to spark plug.
- Pull forward on tine clutch lever to disengage tines. A safety switch prevents engine from starting while tines are engaged.
- Turn shut off to "ON" position.
- Move choke lever on engine to CHOKE position. (A warm engine may not require choking.)
- Move throttle control lever on engine to FAST position.
- Grasp starter handle and pull rope out slowly until engine reaches start of compression cycle (rope will pull slightly harder at this point). Let the rope rewind slowly.
- Pull rope with a rapid, continuous, full arm stroke. Keep a firm grip on starter handle. Let rope rewind slowly. Do not let starter handle snap back against starter.

- Repeat instructions in two preceding paragraphs until engine fires. When engine starts, move choke control gradually to RUN position.
- Allow engine to warm up for a few minutes before engaging tines.

### ATTACHING TILLER TO TRACTOR

(See Fig. 6)

- Rear wheel weights and tire chains can be used on tractor if additional traction is required for tilling.
- Place Tiller on ground level and back up tractor to it.
- Slide Floating Hitch of Tiller onto the tractor drawbar so that the hitch pin holes line up.
- Insert hitch pin until it extends through bottom of Floating Hitch. Insert hair cotter pin into hitch pin.

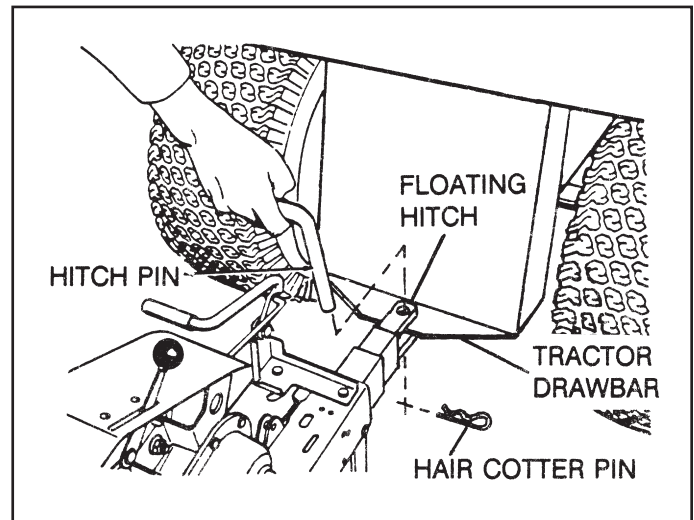

FIG. 6

### BREAKING IN YOUR TILLER

Break-in your belts, pulleys and the control before you actually begin tilling.

- Start engine with tiller attached to tractor in transport position. Engage Tine Clutch Lever to start tine rotation. Allow tines to rotate for five minutes.
- Check tine operation and adjust if necessary. See "TINE OPERATION CHECK" in the Service and Adjustments section of this manual.

## TRANSPORTING YOUR TILLER

### AROUND THE YARD

- Pull forward on lift handle until it locks in the up, transport position.

### AROUND TOWN

- Disconnect spark plug wire.
- Drain fuel tank.
- Transport in upright position to prevent oil leakage.

## TO ADJUST DEPTH STAKE

- Depth stake has five position holes to select tilling depth from 1 to 5 inches.
- The top stake hole selects the shallowest tilling depth and the bottom stake hole selects the deepest position.
- To change depth remove the hair cotter pin from the clevis pin which is connecting the depth stake to the stake support bracket.
- Grasp the top of the depth stake, remove the clevis pin and reposition the depth stake. Insert clevis pin and hair cotter pin.

**IMPORTANT:** THE DEPTH STAKE SHOULD NEVER BE REMOVED FROM THE TILLER. IT IS DESIGNED TO PROTECT THE TRACTOR TRANSAXLE FROM THRUSTING ACTION OF THE TILLER.

## TILLING

- The most efficient tillage is obtained when Tiller Engine is operated at full throttle. The sound of the Tiller Engine will tell you. When Tiller Engine is lightly loaded, raise Gauge Wheels to increase tilling depth. If Engine seems to be overloaded or stalls out, lower Gauge Wheels for shallower tilling.
- Operate Tiller Engine at full throttle and operate tractor in slowest forward speed, with tractor engine at idle speed or just above idle. You will soon learn the proper combination of tilling depth and speed for good tillage.
- Soil conditions will determine how deep Tiller can penetrate on the first pass. In extremely hard ground, several passes may be necessary to till to a depth of 6 inches. While in soft ground, Tiller may penetrate to a depth of 6 inches in the first pass.

## TILLING HINTS

### IMPORTANT OPERATING HINTS

**NOTE:** The following is a general guideline of tilling, but may vary depending upon soil conditions.

- In virgin soil, the tiller should be started in the shallowest depth position and lowered one position at a time after each pass in each position.

- If the soil is extremely hard and dry, it may be desirable to cross till an area at shallow depth first, then till in the direction of planting rows on the second pass at the final depth.
- Where possible, we recommend tilling in a pattern similar to that shown in Fig. 7. Make the first pass, then skip a space equal to the width of the tiller, and make the return pass. Then till the skipped area. Tilling in this pattern will enable you to maintain better control. If the passes were made side-by-side, the tractor and tiller would tend to pull toward the tilled (soft) side.
- Check ground moisture: If you can make a ball in your hand out of ground to be tilled, do not till soil if too wet. This causes lumps which are difficult to work up.
- When operating for the first time, proceed slowly and carefully until you become familiar with the proper method of operating the tiller.
- In soil that was tilled the year before, select the tilling depth at which the tiller engine runs comfortably and does not stall or pull down. Lower depth for additional passes if greater depth is desired.
- Whenever working multiple passes, go perpendicular to the previous tilling direction.
- In cases where the soil is too hard to get proper penetration or if tilling action causes Tiller to hop or bounce, it will be necessary to purchase a set of Tiller (Wheel) Weights.

## CULTIVATING

- Your tiller may be used for cultivating which requires a minimum of two (2) inches of soil penetration.
- Set depth stake so the Tiller will penetrate soil to a depth of 2 to 3 inches. The Tiller Engine should be run at full throttle except when cultivating small plants. A slower engine is necessary to prevent burying the plants. (See fig. 8).

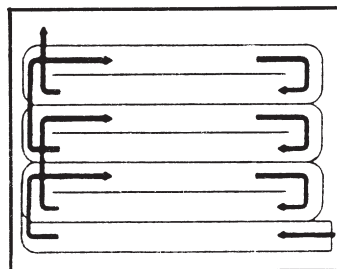

FIG. 7

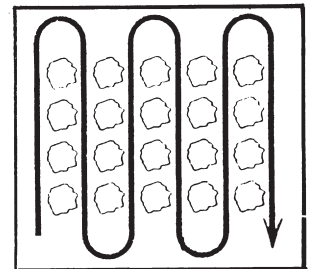

FIG. 8



# MAINTENANCE

## GENERAL RECOMMENDATIONS

The warranty on this Tiller does not cover items that have been subjected to operator abuse or negligence. To receive full value from the warranty, operator must maintain unit as instructed in this manual.

Some adjustments will need to be made periodically to properly maintain your unit. All adjustments in the Service and Adjustments section of this manual should be checked at least once each season.

- Once a year you should replace the spark plug, clean or replace air filter, and check tines and belts for wear. A new spark plug and clean air filter assure proper air-fuel mixture and help your engine run better and last longer.

## BEFORE EACH USE

- Check engine oil level.
- Check tine operation.
- Check for loose fasteners.

## LUBRICATION

Keep unit well lubricated (See "LUBRICATION CHART").

Refer to the engine manual for instructions on engine maintenance.

MAINTENANCE SCHEDULE Fill in dates as you complete regular service.	Before each use	First 5 to 8 hrs.	25 hrs. or every season	50 hrs. or every season	100 hrs. or every season	Yearly	Service Dates											
Check Engine Oil Level	X																	
Change Engine Oil		X		X*														
Service air cleaner precleaner			X**															
Service air cleaner cartridge					X**													
Replace spark plug					X													
Clean cooling system					X**													
Check valve clearance						X												
Check for loose fasteners	X																	
Lubricate Tiller			X															
Lubricate Tiller Transmission			X															

\*Change oil every 25 hours when operating the engine under heavy load or in high temperatures.

\*\*Clean more often under dusty conditions or when airborne debris is present. Replace air cleaner parts, if very dirty.

- REFER TO SEPARATE ENGINE OPERATING & MAINTENANCE INSTRUCTIONS
- REFER TO CUSTOMER RESPONSIBILITIES "TILLER LUBRICATION SECTION."
- GENERAL PURPOSE GREASE

**IMPORTANT:** DO NOT OIL OR GREASE PIVOT POINTS. VISCOUS LUBRICANTS WILL ATTRACT DUST AND DIRT THAT CAN CAUSE WEAR ON PIVOT POINTS. IF YOU FEEL THEY MUST BE LUBRICATED, USE ONLY A DRY POWDERED GRAPHITE TYPE LUBRICANTS.

## LUBRICATION CHART

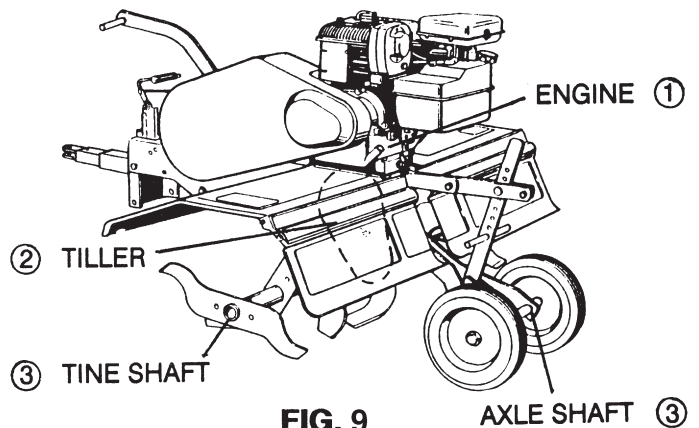

FIG. 9

AXLE SHAFT ③

## TILLER LUBRICATION

Check transmission oil level after first 5 hours of operation. Remove Oil Fill Plug (Fig. 10). Oil Level must be even with the Plug Hole (with Tiller level.) If necessary, add Oil. Use SAE30 Non-Detergent Motor Oil. Replace Oil Fill Plug.

Check transmission oil level after each 10 hours of operation.

**NOTE:** It is not necessary to change the Oil in the Tiller Transmission. If for any reason it must be changed, Oil capacity is 22 oz.

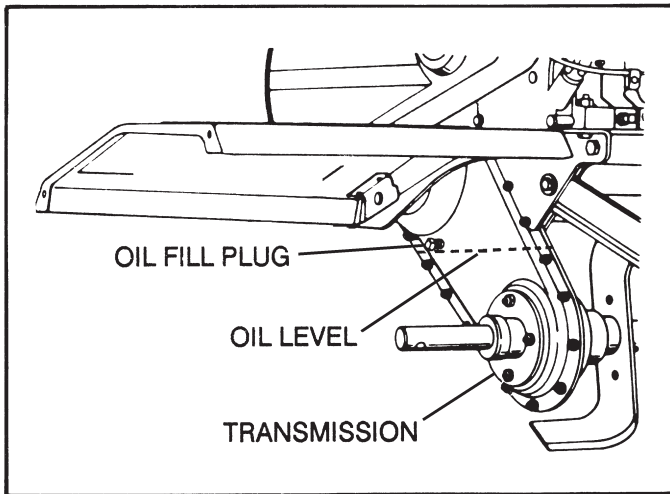

FIG. 10

## ENGINE MAINTENANCE



**WARNING:** Always stop engine and disconnect spark plug wire before cleaning, lubricating or before performing any repairs or maintenance.

- Check **oil level** before each use and every 8 hours.
- Maintain engine oil as instructed in the separate engine manual.
- Service **air cleaner** every 25 hours under normal conditions. Clean every few hours under extremely dusty conditions. Poor engine performance and flooding usually indicates that the air cleaner should be serviced. To service the air cleaner, refer to the separate engine manual.
- **Spark plug** replacement is recommended every 100 hours or yearly. Check the engine manual for correct plug type and gap specifications.

## CLEANING

- Clean engine as instructed in the engine manual.
- Clean wheels, finish, etc. of all foreign matter.
- Keep finished surfaces and wheels free of all gasoline, oil, etc.
- Protect painted surfaces with automotive type wax.

We do not recommend using a garden hose to clean your unit unless the muffler, air filter and carburetor are covered to keep water out. Water in engine can result in a shortened engine life.

## MUFFLER

Do not operate tiller without muffler. Do not tamper with exhaust system. Damaged mufflers or spark arresters could create a fire hazard. Inspect periodically and replace if necessary. If your engine is equipped with a spark arrester screen assembly, remove every 50 hours for cleaning and inspection. Replace if damaged.

## SERVICE AND ADJUSTMENTS



**WARNING:** Shut off (disengage) the Tine Clutch Lever, the Tiller Engine and the Tractor Engine before making any repairs.

### TO REPLACE V-BELT

Replace V-belt if it has been damaged considerably from slipping under heavy loads or if it shows cracks or frayed edges. Refer to figures 11 and 12.

**IMPORTANT:** Do not move or remove the belt guide. If the position of the belt guide is accidentally altered, return it to the correct setting (6-1/2" above the tine shield support plate).

- Remove the screw from the top of the belt guard.
- Remove the hex nut from the rear of the guard.
- Remove the belt guard to allow access to drive belt.
- Disengage tine clutch lever and remove belt.
- Reverse above procedures for installation of new belt.

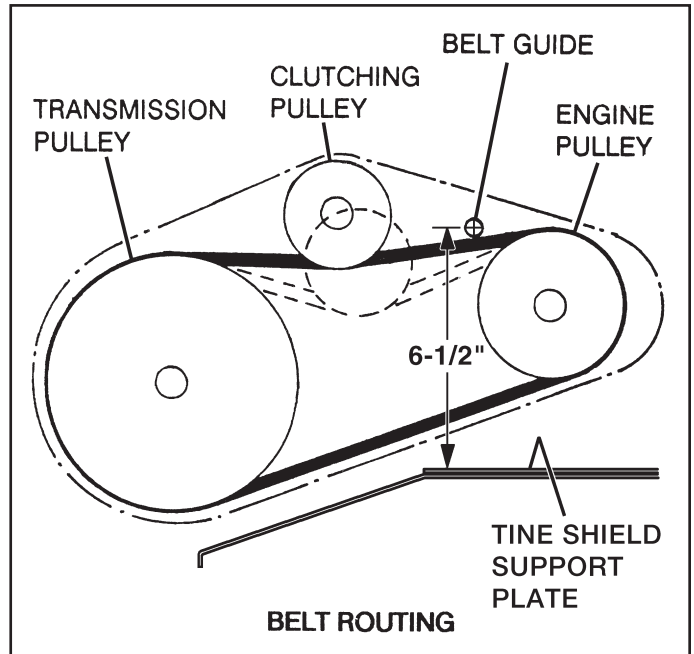

FIG. 12

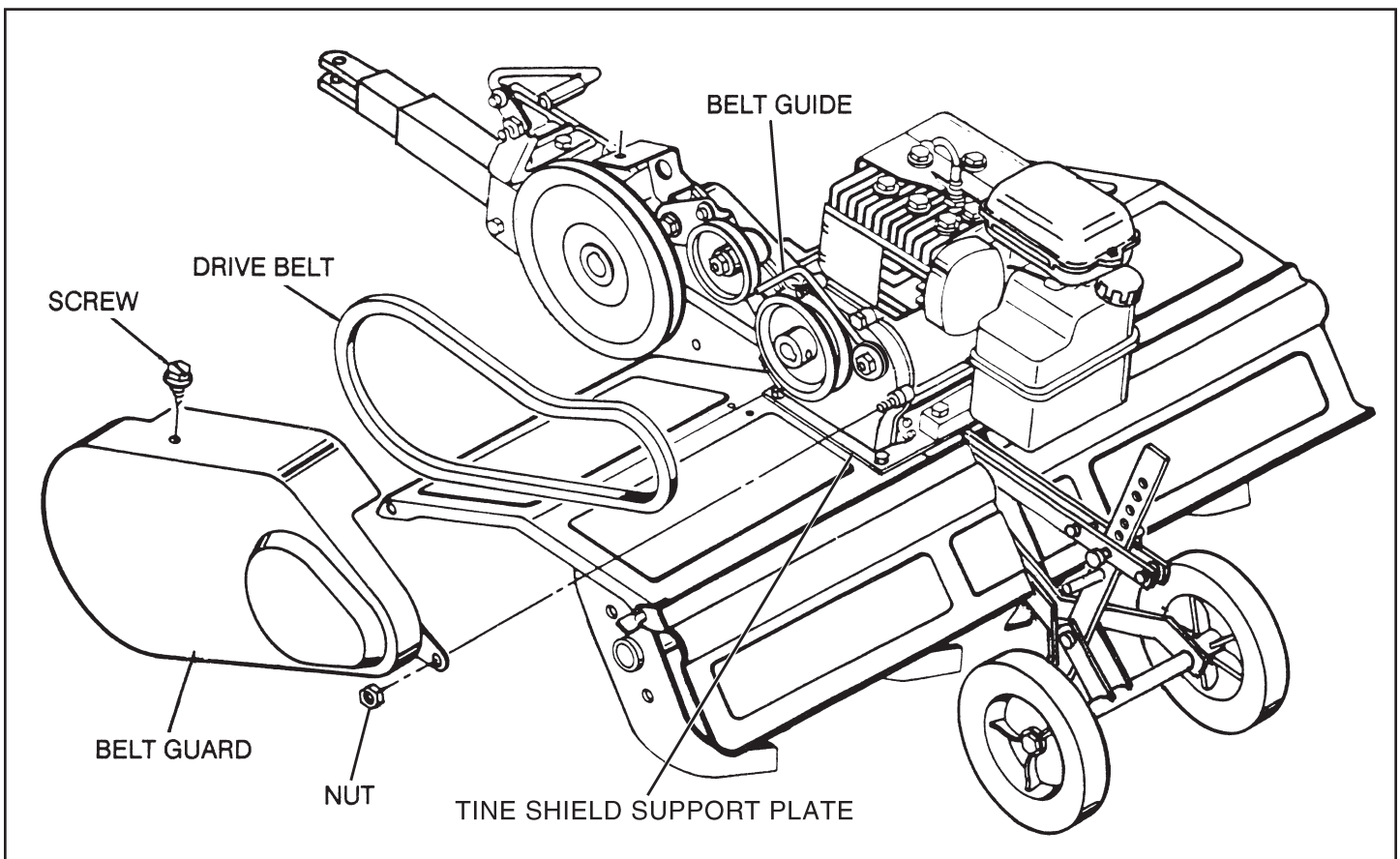

FIG. 11



**WARNING:** Shut off (disengage) the Tine Clutch Lever, the Tiller Engine and the Tractor Engine before making any repairs.

## TINE CARE

- For best results--Tine Blades should be kept reasonably sharp. The Tine Blade can be sharpened on a grinding wheel. Do not attempt to sharpen Tines while they are mounted to Tiller.

## SPARE TINE DRIVE BOLTS

- The Tiller drive components are protected from damage by (shearable) Grade 5 hex bolts in the Tine Assemblies. The hex bolts drive the tines and hold them in the proper location. Should the Tine Assemblies strike or pick up a large hidden object or become jammed, the hex bolts will break and the drive components will not be damaged.
- Two extra tine hex bolts and nuts are included with the tiller. They are located in the Tiller Stake Support Bracket on the rear of the Tiller.
- The tine hex bolts are designed to be loose fit. Do not attempt to use a bolt or pin that is larger or harder than the original Grade 5 hex bolts.

## STORAGE

Immediately prepare your tiller for storage at the end of the season or if the unit will not be used for 30 days or more.



**CAUTION:** Never store the tiller with gasoline in the tank inside a building, where fumes may reach an open flame or spark. Allow the engine to cool before storing in any enclosure.

## ENGINE

- Follow the instructions in the "Service & Storage" section of the Engine Manual.

- Lubricate as instructed in the Customer Responsibilities section of this manual.
- Be sure that all nuts, bolts and screws are securely fastened. Inspect moving parts for damage, breakage and wear. Replace if necessary.
- Touch up all rusted or chipped paint surfaces; sand lightly before painting.
- If possible, store tiller indoors and cover it to protect from dust and dirt.
- Cover tiller with a suitable protective cover that does not retain moisture. Do not use plastic. Plastic cannot breathe, which allows condensation to form and will cause your unit to rust.



**WARNING:** Never cover Tiller while engine and exhaust areas are still warm.

## TILLER

- Clean entire tiller (See "CLEANING" in the Customer Responsibilities section of the manual).
- Inspect and replace belts, if necessary (See belt replacement instructions in the Service and Adjustments section of this manual).

# TROUBLESHOOTING

Follow the instructions in the "Service & Storage" section of the Engine Manual when performing any work on the Engine.

<b>PROBLEM:</b>	
Probable Cause	Possible Remedy
<b>WILL NOT START OR HARD TO START</b>	
No gasoline in Fuel Tank	→ Fill tank with gasoline
Choke not set properly	→ Place Choke Control in "CHOKE" position
Throttle Control not set properly	→ Place Throttle Control in "FAST" position
Choked improperly, flooded Engine	→ Move Choke control to "RUN" position, place Throttle Control in "FAST" position and pull Starter several times to clear out gas
Dirty Air Cleaner	→ Remove to inspect, replace if dirty
Loose Spark Plug Wire	→ Make sure Spark Plug Wire is seated properly on Spark Plug
Spark Plug dirty or improper gap	→ Replace Spark Plug and adjust gap
Water in gasoline or old fuel	→ Drain Fuel Tank and Carburetor, use fresh fuel and replace Spark Plug
Clogged Fuel Tank	→ Remove and clean
<b>ENGINE MISSES OR LACKS POWER</b>	
Engine overloaded	→ Set Depth Stake and Wheels for shallower tilling
Partially plugged Air Cleaner	→ Remove and clean or replace
Dirty Air Screen	→ Clean Air Screen
Spark Plug dirty, improper gap or wrong type	→ Replace Spark Plug and adjust gap
Oil in gasoline	→ Drain and refill gas Tank and Carburetor
Clogged Fuel Tank	→ Remove and clean
Poor compression	→ Major Engine overhaul
<b>ENGINE OVERHEATS</b>	
Low oil level or dirty oil	→ Add or change oil
Dirty Air Screen	→ Clean Air Screen
Dirty Engine	→ Clean Cylinder Fins, Air Screen and Muffler area
Partially Plugged Muffler	→ Remove and clean Muffler
<b>EXCESSIVE BOUNCE AND DIFFICULT HANDLING</b>	
Wheels and Depth Stake incorrectly adjusted	→ Adjust Wheels and Depth Stake
Ground too dry and hard	→ Moisten ground or wait for more favorable soil conditions
<b>SOIL BALLS UP OR CLUMPS</b>	
Ground too wet	→ Wait for more favorable soil conditions
<b>ENGINE RUNS WELL BUT TILLER WON'T MOVE</b>	
Tine Control not engaged	→ Engage Tine Control
V-Belt off of pulleys	→ Check V-Belt
<b>ENGINE RUNS WELL BUT LABORS WHEN TILLING</b>	
Tilling too deep	→ Adjust Depth Stake
Throttle Control not properly adjusted	→ Check Throttle Control setting

# PARTS

## REPAIR PARTS FOR MODEL 486.25244 36" TOW-BEHIND UNIVERSAL TILLER

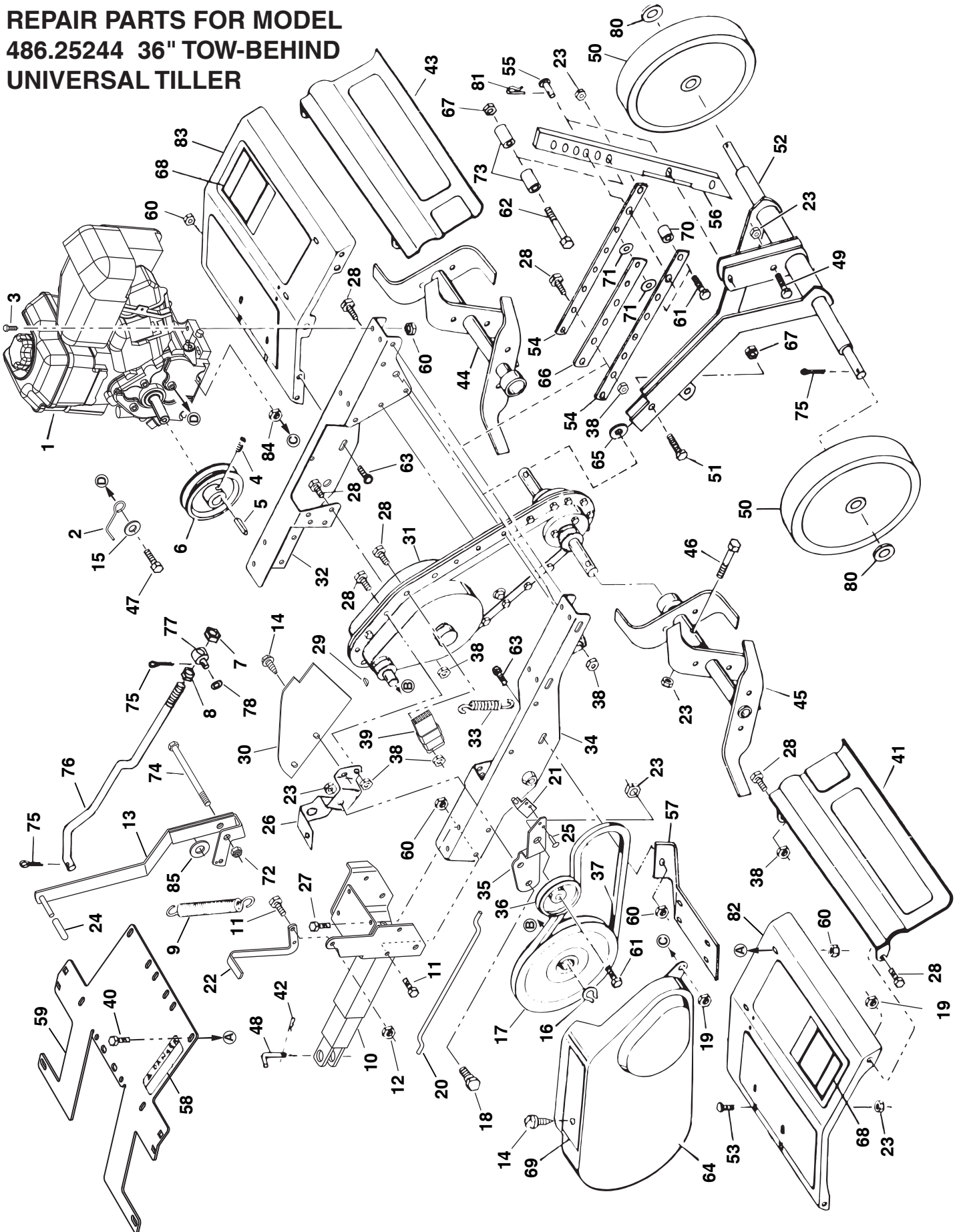

# REPAIR PARTS FOR MODEL 486.252444 36" TOW-BEHIND UNIVERSAL TILLER

REF.	PART NO.	QTY.	DESCRIPTION	REF.	PART NO.	QTY.	DESCRIPTION
1	40993	1	Engine (49 State)	44	HA20094	1	Tine & Hub Assembly - RH
	40997	1	Engine (California)	45	HA20088	1	Tine & Hub Assembly - LH
2	48346	1	Guide - Belt	46	43054	4	Bolt, 3/8-16 x 2"
3	43085	4	Bolt, 5/16-18 x 1-1/2" Hex Head	47	47600	1	Bolt, Hex 5/16-24 x 1"
4	HA115321	1	Screw, 5/16-18 x 5/16"	48	HA5236	1	Pin, Hitch
5	HA11154	1	Key, Square 1/4" x 2"	49	43062	1	Hex Bolt, 3/8-16 x 1-1/2"
6	HA20176	1	Pulley	50	HA20918	2	Wheel
7	48733	1	Nut, 1/2-12 Nylock Jam	51	R74780828	1	Bolt, 1/2-13 x 1-3/4" Hex Head
8	HA124934	1	Nut, 1/2-12 Hex Jam	52	HA20670	1	Pivot Axle Assembly
9	HA19860	1	Spring, Depth Extension	53	43350	8	Bolt, 3/8-16 x 1" Carriage
10	64282	1	Hitch Bracket Assembly	54	HA20725	2	Strap Frame Extension
11	43063	5	Bolt, 5/16-18 x 1" Hex Head	55	HA3433	2	Pin, Clevis
12	43064	1	Locknut, 5/16-18 Hex	56	HA20690	1	Stake, Drag
13	64343	1	Lift Handle Assembly	57	HA20932	2	Wheel Weight Support Bracket
14	48840	3	Screw, Self-Tapping 1/4" x 1/2"	58	HA20940	1	Decal, Danger
15	43081	1	Washer, 5/16" Std. Wrt.	59	25830	1	Plate, Fender Support
16	HA20135	1	Ring, Retainer	60	47810	18	Nut, Hex 5/16-18 Nylock
17	HA20184	1	Pulley, Input	61	41576	5	Hex Bolt - 3/8-16 x 1-3/4"
18	HA20178	1	Bolt - Shoulder	62	R74760884	1	Bolt, 1/2-13 x 5-1/2" Hex Head
19	47189	6	Nut, Hex Nylock 1/4-20	63	44326	2	Bolt, 5/16-18 x 1" Carriage
20	24848	1	Clutch Rod	64	24849	1	Belt Guard (incl. #69)
21	HA23199	1	Switch, Safety Interlock	65	HA14306	1	Washer
22	24847	1	Lever, Clutch	66	HA20691	1	Strap-Frame Extension Brace
23	HA21362	19	Nut, Hex Nylock 3/8-16	67	712-3083	3	Nut, 1/2-13 Nylock
24	HA20170	1	Grip, Handle	68	HA20938	2	Decal, Danger
25	C-9M5732	2	Rivet, Pop	69	HA20942	1	Decal
26	HA20134	1	Bracket, Belt Guide & Idler Mounting	70	HA5713	1	Spacer
27	HA9131	4	Screw, 5/16-18 x 3/4" Self Tap	71	HA15200	2	Washer
28	43661	11	Bolt, 1/4-20 x 1" Hex Head	72	712-0261	1	Nut, Hex 5/18-11 Nylock
29	HA20185	1	Key, Woodruff No. 61	73	HA7974	2	Spacer
30	24863	1	Cover, Drive	74	48278	1	Bolt, Hex 5/8-11 x 7-1/2"
31	HA20119	1	Transmission - Complete	75	43010	6	Pin - 1/8" x 1-1/4" Cotter
32	24843	1	Chassis, Left	76	HA20688	1	Rod - Lift
33	HA20186	1	Spring, Extension	77	HA19649	1	Anchor - Adjustment
34	24844	1	Chassis, Right	78	HA120396	5	Flat Washer, 17/32" x 1-1/6" x .095"
35	24846	1	Bracket, Idler	79	HA124934	1	Nut - 1/2-20 Hex Jam
36	HA11496	1	Pulley, Idler	80	HA456151	4	Flat Washer, 13/16" x 1-1/2" x .134"
37	HA20187	1	V-Belt	81	HA20481	2	Pin - Hair Cotter
38	43013	7	Nut, 1/4-20 Hex Lock	82	HA22594	1	Shield, Tine (LH)
39	64284	1	Module	83	HA22595	1	Shield, Tine (RH)
40	43182	4	Bolt, 5/16-18 x 3/4" Hex Hd.	84	43178	1	Nut, Hex 1/4-20
41	HA20112	1	Rear Guard Assembly - LH	85	R19212113	1	Washer, 5/8"
42	714-0117	1	Pin - Hair Cotter 5/32"		49940	1	Owner's Manual
43	HA20113	1	Rear Guard Assembly - RH				

\*Standard Hardware - Purchase Locally

# REPAIR PARTS FOR MODEL 486.252444 36" TOW-BEHIND UNIVERSAL TILLER

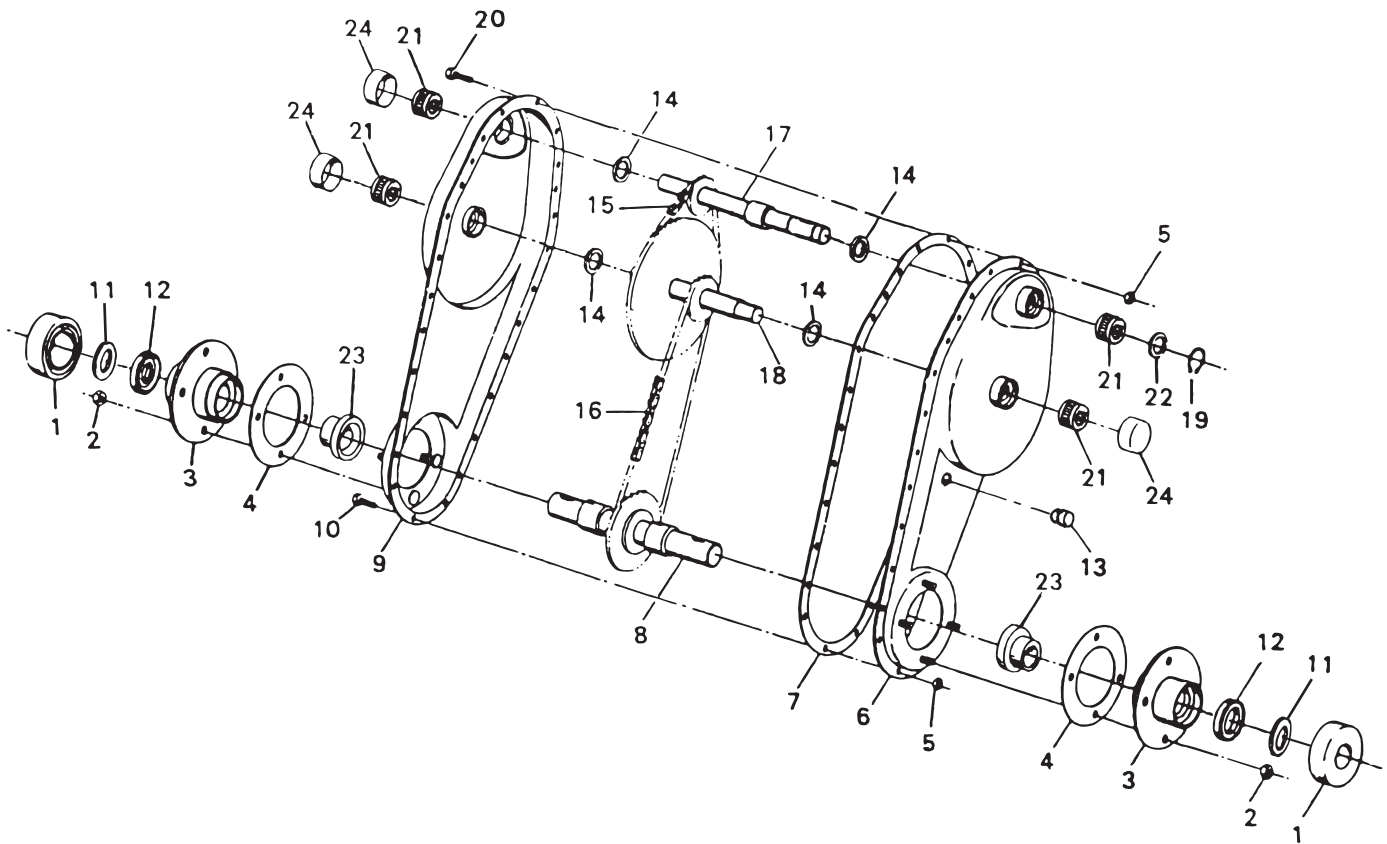

REF.	PART NO.	QTY.	DESCRIPTION
1	HA20344	2	Dust Cap
2	43064	8	Locknut, 5/16-18 *
3	HA20123	2	Flange & Bearing Assy
4	HA20122	2	Gasket, Flange
5	43013	17	Locknut, 1/4-20 Hex *
6	HA20120	1	Drive Housing & Bearing Assy - LH
7	HA20136	1	Gasket, Drive Housing
8	HA20127	1	Tine Shaft Assy
9	HA20121	1	Drive Housing & Bearing Assy - RH
10	43866	15	Bolt, Hex 1/4-20 x 5/8" Grade 8
11	HA20125	2	Washer, Felt
12	HA20124	2	Seal, Rubber
13	HA20130	1	Plug, Transmission Oil
14	HA20129	4	Washer, Thrust
15	HA20132	1	Chain Assembly #40
16	HA20128	1	Chain Assembly #50
17	HA20133	1	Input Shaft Assembly
18	HA20131	1	Idler Shaft Assembly
19	HA20135	1	Ring, Retainer 5/8" Dia. Shaft
20	43012	2	Bolt - 1/4-20 x 3/4" Hex Head *
21	HA20137	4	Bearing
22	HA20145	1	Seal
23	HA20155	2	Bearing, Flange
24	HA20138	3	Cap, Bearing

\*Standard Hardware - Purchased Locally



# NOTES

# NOTES

# NOTES

# Get it fixed, at your home or ours!

## Your Home

For repair – **in your home** – of **all** major brand appliances, lawn and garden equipment, or heating and cooling systems, **no matter who made it, no matter who sold it!**

For the replacement parts, accessories and owner's manuals that you need to do-it-yourself.

For Sears professional installation of home appliances and items like garage door openers and water heaters.

**1-800-4-MY-HOME® (1-800-469-4663)**

Call anytime, day or night (U.S.A. and Canada)

[www.sears.com](http://www.sears.com)      [www.sears.ca](http://www.sears.ca)

*For expert home solutions advice: [www.managemyhome.com](http://www.managemyhome.com)*

---

## Our Home

For repair of carry-in items like vacuums, lawn equipment, and electronics, call or go on-line for the location of your nearest

### Sears Parts & Repair Service Center

**1-800-488-1222** (U.S.A.)      **1-800-469-4663** (Canada)

Call anytime, day or night

[www.sears.com](http://www.sears.com)      [www.sears.ca](http://www.sears.ca)

---

To purchase a protection agreement on a product serviced by Sears:

**1-800-827-6655** (U.S.A.)

**1-800-361-6665** (Canada)

---

Para pedir servicio de reparación a domicilio, y para ordenar piezas:

**1-888-SU-HOGAR®**

(1-888-784-6427)

Au Canada pour service en français:

**1-800-LE-FOYER<sup>MC</sup>**

(1-800-533-6937)

[www.sears.ca](http://www.sears.ca)

